

Hypothetical Plants of Venus And Objects of Unidentified Nature

Leonid V. Ksanfomality, A.S. Selivanov, Yu.M. Gektin

Space Research Institute, Moscow

leksanf@gmail.com

Abstract

The results of a series of Soviet VENERA missions are the only existing direct observations of Venus' surface. Recently, a series of studies was devoted to strange entities in re-processed images that were returned from the surface of the planet Venus by the VENERA landers, 33 and 40 years ago. Experiments in television photography instrumented by the landers VENERA-13 and VENERA-14 (March, 1 and 5, 1982) yielded 37 panoramas (or their fragments) of the Venus surface at the landing sites. The panoramas were re-examined using modern processing techniques and revealed "stems" - objects possessing apparent terramorphic features of Earth-like plants. "Plants" or "stems" are thin knotty vertical trunks on the surface of Venus that have a thickness of 0.3-3 cm and are 0.2 to 0.5 m tall. On close objects, one can see that the "stem" at the top end is provided with a large bulge, a "burgeon" or "flower", with petals surrounding a bright center.

Keywords: Planet Venus; VENERA missions; Astrobiology; Hypothetical flora; Space vehicles instruments

1. REVISION OF DATA OF THE OLD SOVIET VENERA EXPERIMENTS

On March 1 and 5, 1982, experiments in television photography instrumented by the Soviet landers VENERA-13 and VENERA-14, yielded 37 panoramas (or their fragments) of the Venus surface at the landing site [1,2]. Over the past 34 years, no similar missions have been sent to Venus. Analysis of treated once again VENERA-14 panoramic images revealed "stems" objects possessing apparent terramorphic features of Earth-like plants. Due to the availability of up to eight duplicates of the images obtained and their low level of masking noise, the VENERA panoramas permit identifying and exploring some types of hypothetical life forms of Venus. Specifically, "plants" or "stems" are the most numerous group of samples of hypothetical Venusian flora. The first "stems" object was detected due to its being close to the entrance of the TV camera, and the remaining were detected by similarities in their shapes and positions to the first stems.

The VENERA experiments were of extreme technical complexity. The thematic issue of "Kosmicheskiye Issledovaniya", V. XXI, No. 2-3, 1983, presented the main results of the VENERA-13 and -14 missions. The methodology of the television experiments on the surface of Venus and the date and list of the experimental data have been published [2, 3] and are not repeated here. The coordinates of the lander VENERA-13 (March 1, 1982) landing site were 7.5°S, 303.5°E, and its height above the level of radius 6051 km was 1.9 km. The temperature was 735 K (462°C) and the pressure was 8.87 MPa, which corresponds to the atmospheric density 59.5 kg/m³, with the composition CO₂ (96.5%) and N₂ (3.5%). The VENERA-14 lander (March 5, 1982) sank at the equatorial zone too, at 13°S, 310°E, and the landing site's height was 1.3 km above the radius of 6051 km. The measured physical conditions were as follows: The temperature was 738 K, pressure of 9.47 MPa and atmospheric density approximately 65 kg/m³. Gas analyzers repeated that the atmosphere is composed almost entirely of CO₂ (96,5%) and N₂ (3.5%). At both landing sites local time was about 10 am, with a solar zenith angle of 37 and 36°. Illumination by the diffused sunlight was 3-3.5 kLux. For more details see [1-4]. The scene illumination reached 3.5 klx. In both cases, the transmission of images began with a one-minute delay after landing to prevent any dust from obscuring the optical view.

This paper is devoted to "stems", hypothetical Venusian flora. At the time of this writing, five years have elapsed since the submission of the first manuscript for publication that was devoted to hypothetical signs of life on the



planet Venus [2, 3]. These objects hypothetically have characteristics of living creatures - flora or fauna. When experience using image processing was accumulated, the VENERA-14 panorama allowed an approach to the finer details. More information about the properties of the panoramas is presented in [1-3]. An important role was played by additional image processing, image geometric correction and the presence of up to eight duplicates of images that were obtained with good quality and low levels of noise. This arrangement enabled the selection and staking of their fragments. As a result, it managed to find and learn about a few new types of hypothetical living creatures at the VENERA-14 landing site [2].

The interest in the proposed autotrophic flora of the planet as a source of the existence of its fauna was noted in [2, 3]. It is natural to assume that, like on the Earth, the Venusian hypothetical fauna [2] is heterotrophic, and the source of its existence is hypothetical autotrophic flora. Although the direct rays of the Sun, as a rule, do not reach the surface of the planet, there is enough light for photosynthesis of the Earth-like type there. A diffuse illumination of 0.5-5 kLux is sufficient for photosynthesis even in the depths of the dense forests of the Earth. The measured illuminance on Venus is of the same order [4], at the range of 0.4 to 9 kLux. Of course, photosynthesis at high temperatures and in a non-oxidizing environment should be based on a completely different, unknown biophysical mechanism.

2. "STEM" AT THE LANDING BUFFER OF THE VENERA-14.

In input images, a "stem" resembles only a thin scratch, but it is repeated at all panoramas and in the same place (Fig. 1) despite "scratch" in an electronic image is impossible. When processed, the "stems" are vertically arranged thin knotty trunks, which are 0.3-2 cm thick and 0.2-0.5 m (and more) tall. On color panoramas, they

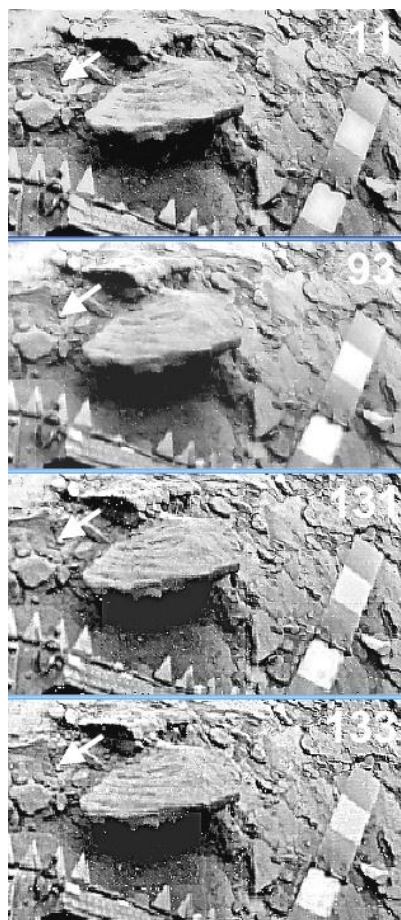

look black. The first object that was detected, which is a "stems" (Fig.2), has a large bulge at the top end, a "burgeon", with a lighter center. The «stems" is located close to the camera. At the "stem" base, on the surface, there is a visible group of details that resembles a quatrefoil. Each of the "leaves" has a size of approximately 5-10 cm, and possibly, they have a radial structure. In the vicinity of VENERA-14, the number of stems at the panorama is approximately eight. All of the "stems" are placed vertically, with the exception of one of the largest, which bends to the surface.

Figure 1. Fragments of the images of the planet surface at the landing site of VENERA-14. A feature under consideration is shown by the arrows. The stacking of the images produces an image shown in upper part of Fig.2.

The clarity of a picture element that has a fixed size depends on the distance. The line resolution was 211 pixels and 11' (arc min); thus, a pixel size corresponding to 0.5 cm (thickness of the "stem") will be placed at the distance $0.005 / (11 / 3438) = 1.56$ m (3438 - the number of minutes in one radian). If the image of a specific object is not single, as in the case of stems, then batch processing and stacking can be used to study the details (Figs. 1, 2).

Figure 2. The first found object of the "stem" type is a thin vertically arranged knotty trunk that has a height of approximately 42 cm and a thickening ("burgeon") on the top. At its base, on the surface, there is a group of details that resembles a quatrefoil. The "stem" is located at a distance of approximately 40 cm from the landing buffer of the VENERA-14 lander and is seen from above. Bottom: a sample of an earthly cruciferous

plant.



Unfortunately, upon heating, the equipment’s adjustment deteriorated, and the actual resolution became worse. In Fig. 2, the knots on the “stems” have a 2-3 pixel size (1-2 cm), and the “bud” has a 5-6 cm size. Based on the geometry of the resulting corners, we can assume that each point of the image of a “stems” that is at a distance of 3 m is eroded by four pixels, and its contrast is reduced by about half (due to the one-dimensional structure of the object). For more remote “stems”, the contrast is reduced; thus, their detection becomes impossible.

To find the height z of the «stems” in Figure 2 one should use geometric relations and a photo plan mosaic (because, on the original panoramas, the distances are significantly distorted). An exact photo plan of the landing site of VENERA-14 is not shown here.

Figure 3. Geometry of the stem imaging (size in cm) and a fragment of the VENERA-14 photo plan. The stem position is shown by “S” arrow.

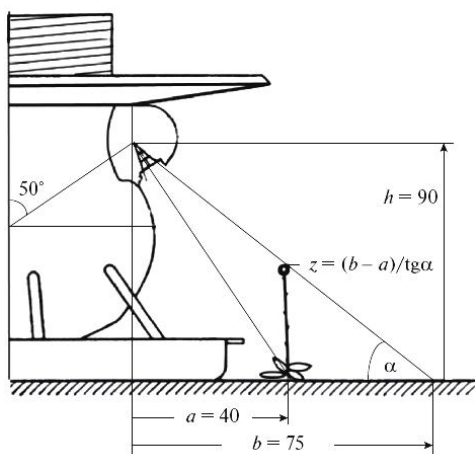

The input window of the TV camera is located at a height of $h = 90$ cm, the distance a from the projection point of the TV-camera lens onto the surface, to the base of the “stems” is approximately 40 cm, and the top of the “stems” is projected onto the surface details, roughly at the distance of $b = 75$ cm. If the “stems” is placed vertically, from the right triangle, then the angle α at its apex is found to be $\text{tg } \alpha = b/h$, and the “stems” height is $z = (b-a)/\text{tg } \alpha = 42$ cm (Fig. 3). A possible error can appear due to the ground surface is uneven.

All of the detected “stems” are thin and apparently knotted. However, perhaps there is one exception. In the peripheral part of the panorama of VENERA-9 (1975), there is an object that could be a thick «stems”. The image shows its light spotted top. Its height is approximately half a meter, the thickness of the “stems” is approximately 5-8 cm, and the nodes are not visible. However, we should be reminded that the low resolution of the VENERA-9 images does not permit making firm conclusions. Another feature on VENERA-9 panorama is shown in section 5.

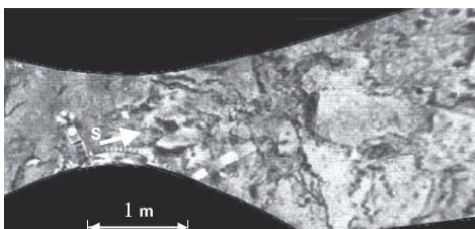
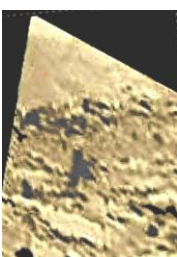

Figure 4. A vertical dark object at the center of the fragment of the VENERA-9 panorama could be a thickened “stem” with a light top.



An interesting peculiarity of the Venusian flora (as well as fauna) is that their day and night are of the very long duration. The annual period of Venus (224.7 terrestrial days), combined with the rotation period (243 days), taking into account the inverse rotation, results in a duration of a sunny day of $T_{sol} = (T_{sid}^{-1} + T_{orb}^{-1})^{-1} = 116.8$ days. Since the rotation axis is almost normal to the orbital plane seasonal effects are absent; day and night are equal to each other and last 58.4 days each.

3. STEMS WITH FLOWERS

To search for other stems, an additional processing of the VENERA-13 and -14 panoramas has been made to improve the clarity of the details. In some of the cases, the correction has been made of geometrically distorted

panoramas. Black-and-white panoramas of VENERA-14 (collected in series—groups 1, 6 and 9, 13 of camera 1 and 3, 5 and 7 and 11 in series of camera 2, together with "red" panoramas of the same series (except for defect series 7) were used, obtained within 2 active hours of the mission. "Green" panoramas are difficult to use because they are noisier. The synthetic color panorama was used to obtain some information about the colors of the objects.

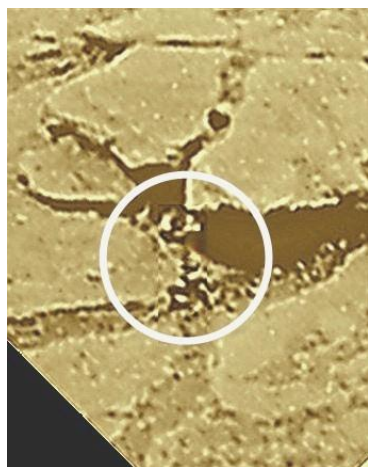

The clarity of details is not the same in different panoramas. Large but distant "stem", perhaps more than half a meter in height, appear to be found in the left-hand edge of the panorama V14-6 and several distant "stems" were found in the right part of the panorama V14-13. In all of the cases, the bases of the "stems" were located in crevices between stones. All of the "stems" that were found are solitary. Figure 5. Processed image: "stem" and "quatrefoil" at its base and details crowning the top of the "stem" at the landing site of VENERA-13. The "stem" is seen in the foreground.

Unlike VENERA-14, at the VENERA-13 landing site only one or two such objects were found, for which the base of the "stems", similar to in Figure 2, were in a crack between the stones. This circumstance can be important because the soil here is mainly fragmented, but the "stems" were not found there. This interesting object is shown in Figure 5, which is a part of four consecutive images of a knotty "stems" that was found in the VENERA-13 panoramas. However, the "stem" in Figure 5 is lower than in Figure 2; it is more distant, and the "stem" itself is not easy to notice, although there are eight distinct images (duplicates), which allows for batch processing. In original images the attention is drawn to the top of the "stem", which appears in duplicates as a triad of bright dots that are visible on all of the original high-contrast images. The position of the triad is not identical in successive frames. It varies slightly with respect to the adjacent stones. This change could arise from the swinging of the triad by the wind that an animation of subsequent images confirms.

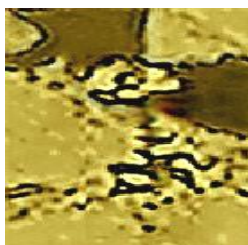

Figure 6. "Flower" - the same object as in Fig. 5 with the opened "burgeon", with lowered contrast and detailed image of the "flower" showing its light central part and leaves at the base. The diameter of the "flower" and the "quatrefoil" at its base are 5-8 cm.

A clearer picture of the "stem" is highlighted in Figure 6. It has been suggested that the complex structure of the top of the "stem" is an opened burgeon. When processing the image with a decreasing contrast, this assumption was confirmed and allowed us to see the whole "flower", of a regular shape (Figure 6) and with a white spot (pestle?) in the center and the surrounding petals. The top of the "stem" is more complex than the triad (or bud in Figure 2). The object is visible from above, and its height, which is found by its position on the photoplan, is only approximately 20-30 cm at the base in the crack between the stones. At its base, there is a group of four bright details, similar to the "quatrefoil" leaves shown in Figure 2; that appears to be associated with the "stem", also. The flower is composed of six to eight light petals. Its right-hand bright part forms the triad, as part of a disclosed flower. The "flower" size is approximately the same as a "quatrefoil" at the base of the "stem". The VENERA-13 panorama has been organized in such a way that Fig. 3 represents only a fragment of the black-and-white image; thus, one can talk about only the bright colors of the petals, and their color in

Figs. 5, 6 is unknown.

Another interesting but unobtrusive small bright quatrefoil was detected at the center of the VENERA-14 panoramas in a depression that is quite near to the landing buffer (Fig. 7, see frames 1 and 2). In contrast to Fig. 2, its "leaves" are very bright, only slightly darker than the white cap released from the TV camera. One of the quatrefoil elements is in the shadow of a stone. The dimensions of the "leaves" are not more than 2 cm. Despite its smaller size, the object similarity with Fig. 2 is obvious. The "stem" itself on the source panoramas (frame 1) is difficult to see; it was isolated by using a gamma-correction and in such a form is shown in column 4 as consecutive original pictures (Fig. 7, frame 3). The height of the plant observed from above is approximately 10 cm. There is a "flower" seen on its top, also. When the image is processed, the "stem" gets viewed as in Fig. 7, frame 4. The dimensions of the "flower" are approximately 2 cm, also. To the right of it, another "flower" is visible, the "stem" of which apparently is placed behind the stone.

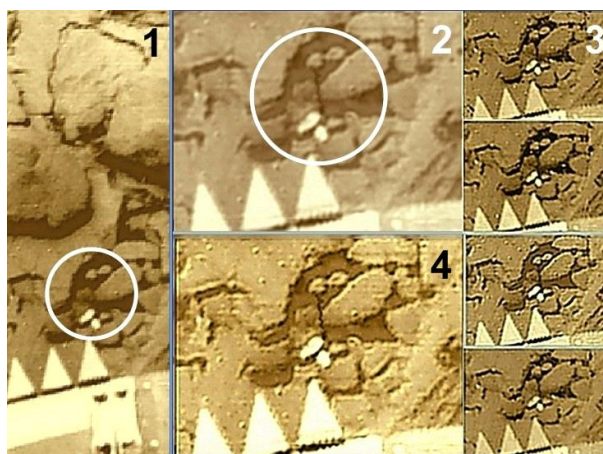

Fig. 7. "Stem" (frames 1, 2) with a bright "quatrefoil" located directly at the landing buffer of VENERA-14; its recurring images are shown on four consecutive panoramas (column 3). The processed stacked image is shown in frame (4). To the right of the "flower", there is another "flower" seen, the "stem" of which is apparently situated behind the stone.

In Fig. 7, "stem" and "flower" are seen against the background of contrasting details and cracks in the stone slab recess. The "stem" rises from the recess. The object is relatively close to the camera (less than 1 m), but the "flower" is small, and compared with Figure 6, the resolution is low.

There is another fragment of the supposed "plant" refers to the VENERA-14 panorama, for which there is a color version. Therefore, it is possible to obtain some information about the color of the object. The initial color separation of the VENERA images cover the spectral ranges 390 - 510 nm (blue, useless due to the almost complete absorption by the atmosphere), 490 - 610 nm (green), 590 - 720 nm (red filter) and 410 - 800 nm (no filter).

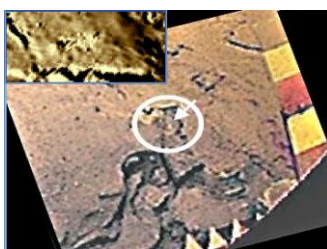

Fig. 8. Two possible plants on the color fragments of the VENERA-14 image.

The solar energy distribution at the surface in the range of 410 to 800 nm has a maximum in the nearest infrared region [4]. Thus, colorful panoramas and fragments can be considered conditionally as tricolor. In this sense, the flowers shown in it (Fig. 8), when compared with the background, have a greenish tint. However, the identification of the object is made with the least confidence among the other figures. The spotty nature of the surface and numerous cracks complicate the identification of the object. Similar to the terrestrial flora are "stems" (Fig. 9), located in different parts of the VENERA-14 panorama. They are distant and their details are difficult to distinguish.

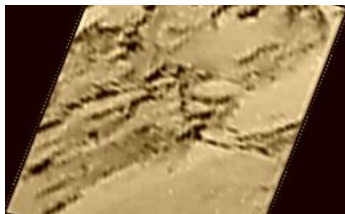
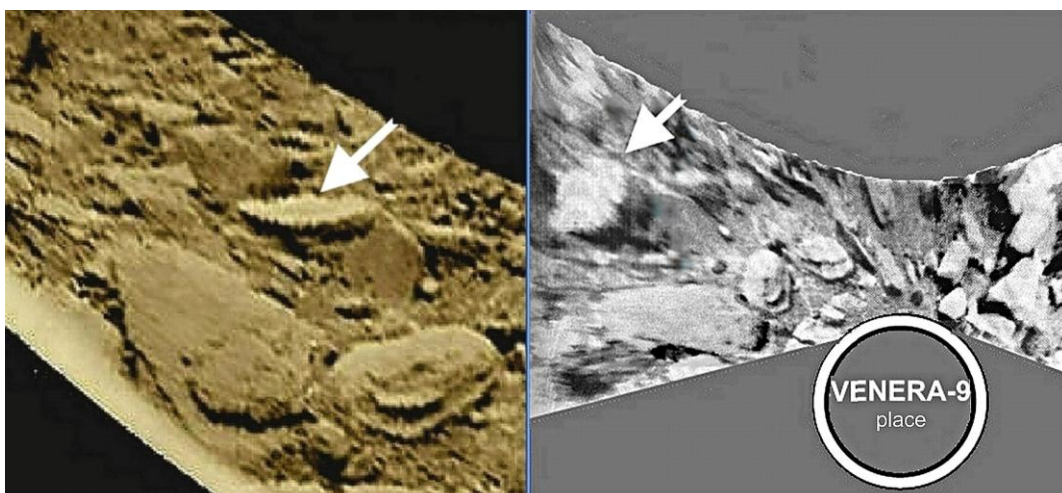

Fig. 9. One of distant stems on the VENERA-14 panorama. Does it cast a shadow?

4. ON A POSSIBLE ROLE OF BURGEONS AND FLOWERS

The landing site around the landers VENERA-13 and VENERA-14 showed a significant number of vertically oriented objects that were similar to the «stems» of terrestrial plants. The "stems" are an important complement to the objects of a hypothetical Venusian flora discussed in [2, 3]. If the tops of the "stems" really are burgeons and flowers, one should reflect their role. The flowers of terrestrial plants are intended for their pollination and reproduction. Pollination is conducted either by insects or by the wind. Wind-pollinated plants do not require blooms in principle, for example, the case of the poplar "fluff." Flowers attract insects. Do the tops of the "stems" in Fig. 2, 5-7, at least indirectly, hint on the likely participants in the process of pollination? Terramorphism of hypothetical objects of the flora and fauna of Venus was observed repeatedly in many entities [2, 5, 6] for example, a terramorphic object [2] "mushroom". Flowers with their petals in Figures 5 and 6 are new objects that are surprising to find, and it is surprising to find the occurrence of the same forms of living objects on different planets that have radically different physical conditions. However, what are the laws of nature that determine the recurrence of terramorphism hidden in such markedly different environments? The Earth's flora began the evolution of carbon dioxide in an oxygen-free atmosphere, for which the composition was similar to the current atmosphere of Venus. Did the Venusian flora evolve to exist in its physical settings? And to conclude with, the illumination on the surface of the planet Venus energetically



complies with photosynthesis. What could be the mechanism of the Venusian photosynthesis?

5. OBJECTS OF UNIDENTIFIED NATURE

few tens of published papers are devoted to a dozen of most prominent objects of hypothetical living nature that were found on Venus. A part of other findings could be either unusual geological forms of the planet's surface or nonterramorphic endemic hypothetical living entities. The relevant examples are the "luger"

and "skittles" discussed in [7], not repeated here.

Fig. 10. "Jaggy" object (arrow) on the processed VENERA-9 panorama (left) and its horizontal projection (photo plan, right). The circle shows the position and size (2m) of the VENERA-9 lander.

On processed VENERA-9 panorama considered in [2], a large elongated bright object stands in having the size about of 1.5 m, with a strange jagged edges, resembling earthly jagged leafs of trees. Initially it was supposed that its jagged edges are results of a linear structure of the TV image, however it is not a case for surrounding details. It is nicknamed "Jaggy" and is much lighter than the surface of surrounding stones.

"Jaggy" rose above the surface, with a deep shadow visible under it. Due to the large distance from the camera (approximately 5 m), the object structure is difficult to define. For some extent, a photo plan (mosaic) could help. Unfortunately, there is only a working version of the mosaic based on the VENERA-9 primary data processing. Nevertheless, it can be seen that in comparison with the surrounding boulders that the "Jaggy's" structure is more complicated (Fig. 10); guessed is a radially and radiant appearance of it's periphery. The photo plan one may considered as a horizontal projection of "Jaggy" which is more reminiscent of a sea stingray. The photo plan resolution is low and does not allow drawing any specific conclusions about the nature of "Jaggy" and even more so to attribute it to the flora or fauna. There are few smaller features on Fig. 10 having jagged edges, too.

The elongated shape of details in the edge of the Fig. 10 is the more pronounced, the farther they are away from the center, so the object view could be deceiving. It should be recalled that the resolution of the VENERA-9 camera was 21', twice worse than that of the VENERA-13 and -14; so attempts of identifying the "Jaggy" nature should be treated with caution.

CONCLUSION

For thousands of years, humanity has wondered whether there is life outside the Earth. Recently, a series of studies was devoted to strange entities in TV images that were returned from the surface of the planet Venus by the Soviet VENERA landers, 33 and 40 years ago. The TV method was the same that is used nowadays for a search of hypothetical martian life. The images were re-processed using modern processing techniques. There are entities that one can consider to be signs of hypothetical life on Venus, regardless of how strange this assumption sounds. The pictures revealed a dozen previously undetected strange objects that can attest to the fact that Venus does possess life. Materials shown in this paper demonstrate experimental results that involve re-processing of the original panoramas, without any retouching or corrections. For the moment, it is impossible to prove that the objects are alive in fact because they cannot be touched. However, the opposite is true also, that nobody can show errors in the processing of the images. Instead, many scientists believe that life on Venus is absolutely impossible, therefore, it does not worth studying our finds. As it is known, there is IAU committee of IAU Commission F3, Astrobiology, with the chairman of it, Mr. Sun Kwok. The IAU GA XXIX was held in Honolulu, August 2015. When at a meeting of the commission, the author of this paper suggested that the Commission should be informed about the hypothetical finds on Venus, the committee members stood up and left the meeting. The Commission's behavior is a good example of obstruction that has been made by "scientists" who are exploring the Astrobiology. Subconsciously, all positions of critics have been based on variations of the statement: only the Earth's physical conditions are suitable for life. Based on this idea, limited "habitable zones" are drawn in schemes of extrasolar planet systems and are under the study of theoreticians.

No other possibilities are considered.

Hypothetical stems and flowers with their petals shown above are new objects that are surprising to find. It is strange to find the occurrence of the same forms of living objects on different planets that have radically different physical settings. We call this strange repetition of terrestrial forms terramorphism. The discovery of this phenomenon is no less important than that of the extraterrestrial life itself. Certainly, the phenomenon relates to most deep problems of the search for life in the Universe.

REFERENCES

1. Selivanov, A.S., Gektin, Yu.M., Gerasimov, M.A., Nosov, B.I., Naraeva, M.K. *et al.* Continuation of the TV Investigation of Venus surface by means of landers. *Kosmich. Issled.*, **21**, No. 2, 176-182 (1983).
2. Ksanfomality, L.V. Possible signs of life on the planet Venus. *International Journal of Astronomy and Astrophysics (IJAA)*, **3**, 57-79 (2013).
3. Ksanfomality, L.V. Hypothetical flora and fauna of Venus. *Acta Astronautica*, 2014, V.105, pp. 521-533.
4. Moshkin, B. E., Economov, A. P., Moroz, V. I., Golovin, Yu.M., Gnedih, V.I., *et al.* Spectrophotometric experiment on VENERA-13, -14 landers. *Kosmich. Issled.*, **21**, No. 2, 236-245 (1983).
5. L.V. Ksanfomality, A.S. Selivanov & Yu.M. Gektin Possible Signs of Flora on the Planet Venus // *Global Journal of Science Frontier Research: A Physics and Space Science* Volume 14 Issue 4 Version 1.0 Year 2014. Online ISSN: 2249-4626 & Print ISSN: 0975-5896.
6. L.V. Ksanfomality, A.S. Selivanov & Yu.M. Gektin. New Type of Hypothetical Venusian Fauna Found at the Venera -14 Landing Site // *Global Journal of Science Frontier Research: A Physics and Space Science* Volume 15 Issue 3 Version 1.0 Year 2015. Online ISSN: 2249-4626 & Print ISSN: 0975-5896.
7. L.V. Ksanfomality. Intermediate Results of Investigating Hypothetical Venusian Fauna // ISSN 1028-3358,
8. *Doklady Physics*, **59**, No. 10, 498–502 (2014).

FIGURES LEGENDS

Figure 1. Fragments of the image surface of the planet at the landing site of VENERA-14. A feature under consideration is shown by the arrow. Their stacking produces an image shown in Fig.2.

Figure 2. The first found object of the "stem" type is a thin vertically arranged knotty trunk that has a height of approximately 42 cm and a thickening ("burgeon") on the top. At its base, on the surface, there is a group of details that resembles a quatrefoil. The "stem" is located at a distance of approximately 40 cm from the landing buffer of the VENERA-14 lander and is seen from above. Bottom: a sample of an earthly cruciferous plant.

Figure 3. Geometry of the stem imaging (size in cm) and a fragment of the VENERA-14 photo plan. The stem position is shown by "S" arrow.

Figure 4. A vertical dark object at the center of the fragment of the VENERA-9 panorama could be a thickened "stem" with a light top.

Figure 5. Processed image: "stem" and "quatrefoil" at its base and details crowning the top of the "stem" at the landing site of VENERA-13. The "stem" is seen in the foreground.

Figure 6. "Flower" - the same object as in Fig. 5 with the opening "burgeon", with lowered contrast and detailed image of the "flower", showing its light central part and leaves at the base. The diameter of the "flower" and the "quatrefoil" at its base are 5-8 cm.

Fig. 7. "Stem" (frames 1, 2) with a bright "quatrefoil" located directly at the landing buffer of VENERA-14; its recurring images are shown on four consecutive panoramas (column 3). The processed stacked image is shown in frame (4). To the right of the "flower", there is another "flower" seen, the "stem" of which is apparently situated behind the stone.

Fig. 8. Two possible plants on the color fragments of the VENERA-14 image.

Fig. 9. One of distant stems on the VENERA-14 panorama. Does it cast a shadow?

Fig. 10. "Jaggy" object (arrow) on the processed VENERA-9 panorama (left) and its horizontal projection (photo plan, right). The circle shows the position and size (2m) of the VENERA-9 lander.